

# Design of a Compact Internal Multiband Antenna for Mobile Phones and WLAN Applications

<sup>#</sup>Rashid Ahmad Bhatti, Hyung Sik Yoon and Seong-Ook Park, *Member IEEE*  
 Microwave and Antenna Lab, School of Engineering, Information and Communications University  
 Munji dong, Yuseong-gu, Daejeon, South Korea  
 E-mail: [rab2138@yahoo.com](mailto:rab2138@yahoo.com), [sopark@icu.ac.kr](mailto:sopark@icu.ac.kr), [gunjong7@icu.ac.kr](mailto:gunjong7@icu.ac.kr)

## 1. Introduction

Modern mobile phone handsets are required to operate at multiple frequency bands to provide various communication services [1]-[3]. The demand of compact, light weight, and multifunctional handsets puts more stringent requirements on the antenna design. Novel antenna designs are needed to meet the requirements of these emerging trends in mobile communication. Being compact and low profile, planar inverted-F antenna (PIFA) is a potential structure as a basic element to realize multiband personal communication handset antennas [4]-[5]. Basic PIFA structure has limited bandwidth of 4 % to 12 % for 10 dB return loss [6] - [7]. However, variants of PIFA structure in combination with other broadbanding techniques can be utilized to realize antennas with multiband performance. Various quad-band and hexa-band PIFA based designs are reported in the literature [2], [3], [7] - [12]. These antennas occupy a volume ranging from 4.6 cm<sup>3</sup> to 5.2 cm<sup>3</sup>. Excessive height of 7 mm or 8 mm makes these antenna structures unattractive for modern slim handsets that require reduced height antennas. Operation at 5.2 GHz for Wireless Local Area Network applications are also required for future personal communication handsets. Therefore, the antenna design with eight or more bands in the limited available space, while maintaining the antenna radiation efficiency and return loss performance in each band, is a major challenge for the mobile phone antenna designer.

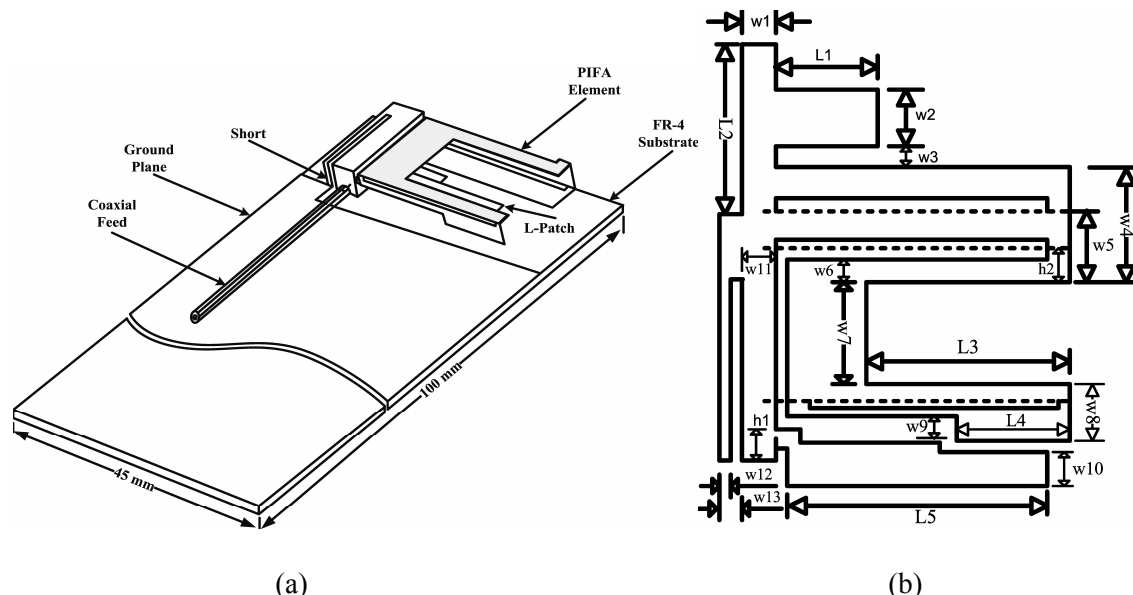

Figure 1: Geometry of the proposed antenna (a) 3-D view (b) Planar view with dotted bending lines

In this paper, a novel PIFA based antenna is proposed as an internal antenna for mobile handsets. The antenna is designed to operate at GSM (890-960 MHz), DCS (1710-1880 MHz), PCS (1880-1990 MHz), UMTS (1900-2200 MHz), WiBro (2300 -2390 MHz), (ISM (2.4-2.48 GHz), Bluetooth and WLAN (5.17-5.5 GHz) frequency bands. The antenna consists of a basic PIFA radiator, L-

patch located beneath the PIFA element and directly connected to the feed pin and an additional resonating strip for operation in WLAN band around 5.2 GHz. A prototype antenna is fabricated using a flat copper sheet of 0.2 mm thickness and characterized for return loss and radiation performance. Comparison between the measured and simulated results is given in the paper.

## 2. Antenna Design

Ever shrinking size of the personal communication handset demands the reduced height antennas that occupy less volume. Moreover, due to the emergence of new standards and the user's mobility requirements, mobile terminal should cover multiple standards. Therefore, it is important to develop antennas for these mobile terminals that can cover multiple frequency bands. Commonly the conventional techniques to realize antennas with multiband operation include the use of multimode excitation in the structure by using slots in the main radiating element, parasitic patches for broadbanding and impedance matching and quarter wave resonating strips connected to the feed path at appropriately selected locations. With multiple bands, antenna volume should not increase beyond the acceptable range. Size reduction is usually achieved using shorting pins, stubs, capacitive loading and folding or meandering the resonators in an appropriate form. The most popular technique to implement small multiband antenna is to use quarter wave resonators with Planar Inverted-F Antenna (PIFA) [13].

In this paper, an eight band reduced height antenna is proposed for slim personal communication handsets. Antenna is designed in the rectangular area of 30 mm × 15 mm with a height of 4 mm and located at top of the ground plane of FR-4 ( $\epsilon_r = 4.2$ ,  $h = 0.8$  mm) substrate measuring 85 mm × 45 mm. Total volume of the antenna is 1.8 cm<sup>3</sup> that is a significant reduction in volume in comparison with volume of the antennas reported in the literature [2] - [12]. The proposed antenna configuration with different views and dimensional details is depicted in Fig. 1. The basic antenna element is a dual band conventional inverted-F patch. One end of the PIFA element is grounded through a short circuiting pin and the other end is folded to reduce over all size of the antenna. Resonance at GSM band is achieved by selecting length of the longest PIFA element close to the quarter wavelength at 910MHz. Second resonance is exhibited close to the centre frequency of the PCS band, but the bandwidth is not sufficient to cover the PCS and the neighbouring bands. In order to enhance the bandwidth for operation from DCS to Bluetooth frequency band, an L patch is inserted beneath the main PIFA radiating element. The L-patch is directly connected to the feed pin at a judiciously selected location. Length ( $L_5$ ), width ( $w_{10}$ ) and height ( $h_1$ ) of the L-patch are optimized for wide bandwidth performance of the antenna from PCS to Bluetooth frequency bands. Length of the L-patch primarily determines the lower frequency of operation while the width has more influence on the upper frequency edge of 2.5 GHz. Selection of both length and width of the L-patch is not independent completely, but within certain limit they behave almost independently for bandwidth optimization. Variation in width under certain bounds does not influence the lower edge of DCS band, GSM band and the WLAN 5.2 GHz frequency band. However, length of the L-patch strongly affects the WLAN band. Height of the L patch is selected for better impedance matching performance. Feed strip is bended to excite the structure at multiple points for wideband impedance matching performance. In order to get resonance for WLAN operation at 5.2 GHz frequency band, a small resonating strip of length  $L_1$  and width  $w_2$  is attached to the feed line at an appropriate position. Length of the strip is selected to get resonance at 5.2 GHz and width is optimized for bandwidth performance. For a suitably selected location on the feed line, optimization of this resonating strip has very little effect on the performance of other resonators and their bandwidth remains unchanged under the dimensional variations of this strip. Inclusion of the WLAN resonating strip at this location does not affect the antenna volume, other frequency bands, and also it does not complicate the antenna manufacturing process as well. Width of the shorting strip affects the impedance matching performance of the antenna. Width  $w_{12}$  for the shorting strip is selected for optimum impedance matching performance over the required frequency bands. Dimensional details of the proposed antenna structure are given in Table-1. Fabrication of the proposed antenna is quite inexpensive and straight forward. The antenna is fabricated using a

planar copper sheet of 0.2 mm thickness. The antenna is then bended at the locations shown dotted in Fig.1(b), to realize the three dimensional structure.

Table 1: Dimensional details of the proposed antenna

Parameter	Value (mm)	Parameter	Value (mm)	Parameter	Value
$W_1$	2.7	$W_4$	11.7	$W_8$	5.5
$h_1$	1.9	$L_3$	18.6	$W_9$	1.5
$L_1$	10	$W_5$	6.7	$W_{10}$	3.1
$W_2$	5.0	$L_4$	10.5	$W_{11}$	2.7
$h_2$	2.7	$L_5$	20.0	$W_{12}$	0.8
$L_2$	15	$W_6$	2.0	$W_{13}$	1.6
$W_3$	1.0	$W_7$	10.5	$W_{14}$	1.0

### 3. Simulation and Measured Results

Ansoft High Frequency Structure Simulator (HFSS) is used for full wave analysis of the multiband antenna structure. Antenna structure is tuned to get optimum bandwidth at all frequency bands with return losses better than -10 dB and acceptable radiation performance. Return losses for different antenna structural configurations are plotted in Fig. 2. Antenna with only basic Planar Inverted-F Antenna (PIFA) radiating element is tuned at GSM band and second resonance occurs close to 2.0 GHz but that is not sufficient to cover the intended bandwidth. The structure exhibits wide band performance when L-patch is inserted beneath the Planar Inverted-F Antenna (PIFA) radiator. The bandwidth improves starting from the DCS band to the Bluetooth frequency range and also it helps to improve the return loss at GSM frequency band. Inclusion of the resonating strip for WLAN operation helps to improve the return loss at 5.2 GHz without adversely affecting the other frequency bands.

A prototype antenna is fabricated from a thin copper sheet of 0.2 mm thickness and bended to get the desired 3-D antenna structure. Antenna characterization is done by measuring its reflection loss and far-field radiation pattern. Measured and simulated return losses are compared in Fig. 3.

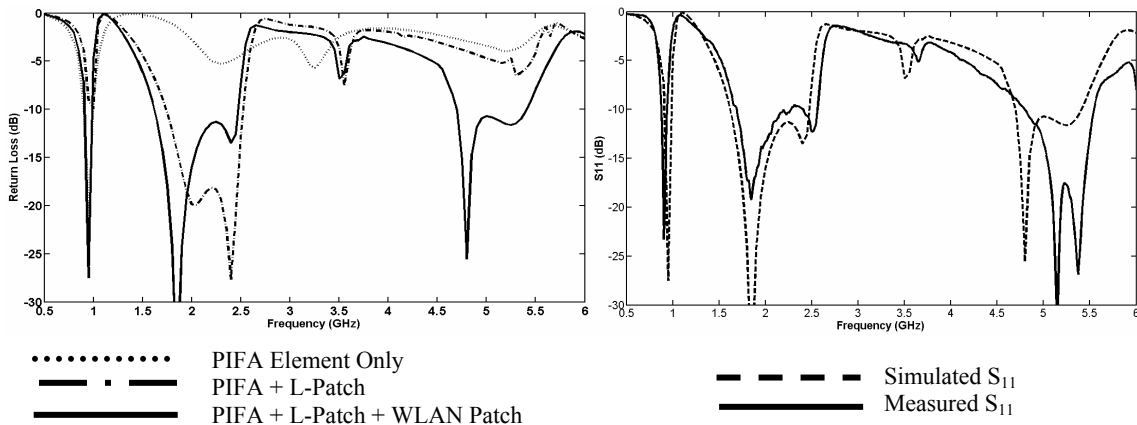

Figure 2: Simulated  $S_{11}$  for various structural configurations of the antenna

Figure 3: Comparison between the measured and simulated return losses

Measured return loss is better than -10 dB at all the frequency bands. Far field radiation patterns are measured in an anechoic chamber and good radiation performance is achieved. Radiation patterns in x-y plane, x-z plane, and y-z plane at 900 MHz, 2100 MHz and 5200 MHz are plotted in Fig. 4. Radiation patterns at other frequencies are not shown in the paper.

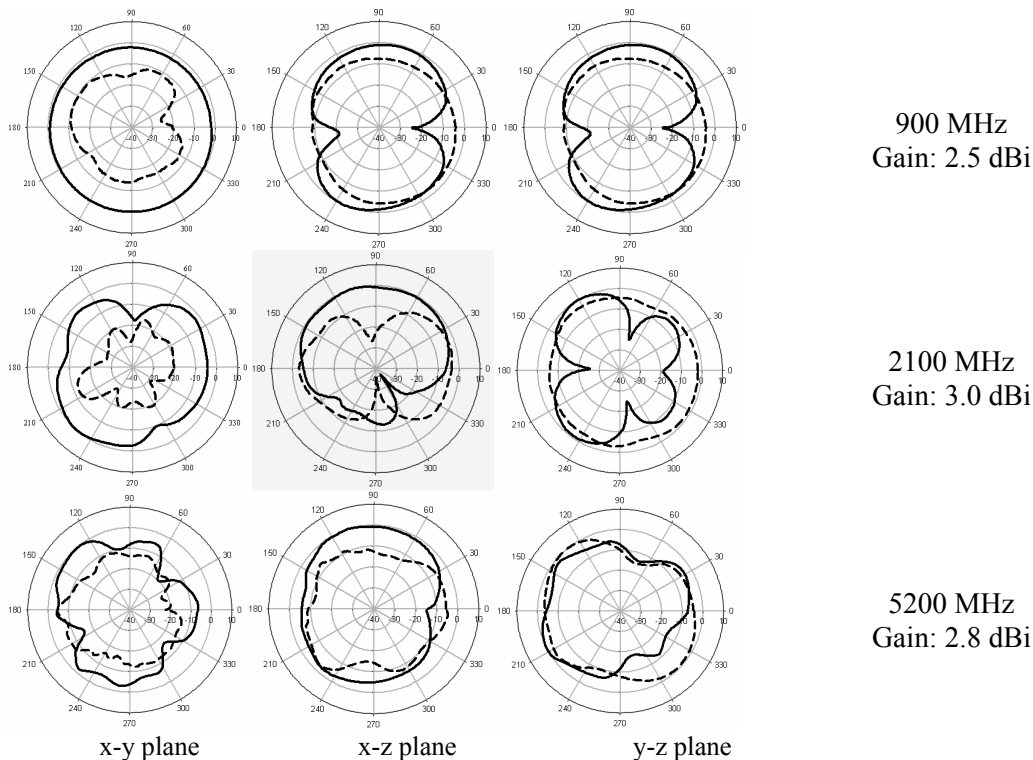

Figure 4: Measured radiation pattern of the antenna (— Co-polarization, - - - Cross polarization)

## 4. Conclusions

A PIFA based multiband internal antenna has been proposed for personal communication handsets to operate at GSM, DCS, PCS, UMTS, ISM, WiBro, Bluetooth, and 5.2 GHz WLAN bands. Measured  $S_{11}$  of the antenna is better than -10 dB at all the bands with good radiation performance. Over all volume of the antenna is  $1.8 \text{ cm}^3$  that makes it attractive for modern slim personal communication handsets.

## References

- [1] Y. X. Guo, M. Y.W. Chia and Z. N. Chen, "Miniature built-in quadband antennas for mobile handsets", *IEEE Antennas Wireless Propag. Lett.*, vol. 2, pp. 30-32, 2004.
- [2] P. Ciaia, R. Staraj, G. Kossiavas, and C. Luxey, "Design of an internal quadband antenna for mobile phones", *IEEE Microwave Wireless Comp. Lett.*, vol. 14, no 4, pp 148-150, April, 2004.
- [3] I. Ang, Y. X. Guo, and Y. W. Chia, "Compact internal quad-band antenna for mobile phones", *Micro. Opt. Technol. Lett.*, vol. 38, no. 3 pp. 217-223 Aug. 2003.
- [4] *Mobile Antenna Systems Handbook*, 2<sup>nd</sup> ed., K. Fujimoto and R. J. James, Eds., Artech House, Norwood, MA, 2001.
- [5] Ying-Xin Guo, Irene Ang., and M. Y. W. Chia, "Compact Internal Multiband Antennas for Mobile Handsets", *IEEE Antennas and Wireless Propagation Letters*, vol. 2, pp 143-146, 2003.
- [6] C. R. Rowell and R. D. Murch, "A compact PIFA suitable for dual frequency 900/1800-MHz operation," *IEEE Trans. Antennas Propag.*, vol. 46, no. 4, pp. 596-598, April 1998.
- [7] Hoon Park, Kyungho Chung, and Jaehoon Choi, "Design of Planar Inverted-F Antenna With Very Wide Impedance Bandwidth", *IEEE Microw. & Wireless Comp., Lett.*, vol. 16, no. 3, pp. 113-115, March, 2006.
- [8] Yong-Xin Guo, Heww Siang Tan, "New Compact Six-Band Internnal Antenna," *IEEE Antennas and Wireless Propagation Letters*, Vol. 3, pp295-297, 2004.
- [9] Hoon Park, Myoung il Kang, and Jaehoon Choi, "Design of an Internal antenna with wide and multiband characteristic for mobile handset", *IEEE Microw. & Opt. Tech. Lett.* vol. 48. no. 5, May, 2006.
- [10] Cheng-Nan Hu, Willey Chen, and Book Tai, "A Compact Multi-band Antenna Design for Mobile Handsets", *APMC 2005 Proceedings*.
- [11] Marta Martinez-Vazquez, Oliver Litschke, Mathias, Dirak Heberling, Antonio M. Martinez-Gonzalez and David Sanchez-Hernandez, "Integrated Planar multiband Antennas for Personal Communication Handsets", *IEEE Transactions on Antennas and Propagation*, vol. 54, no. 2, Feb. 2006.
- [12] P. Ciaia, R. Staraj, G. Kossiavas, and C. Luxey, "Compact Internal Multiband Antennas for Mobile Phone and WLAN Standards", *Electronic Letters*, vol. 40, no. 15, pp. 920-921, July, 2004.
- [13] K.-L Wong, *Planar Antennas for Wireless Communications.*, Hoboken, NJ: Willey, 2003, ch. 2.